

Technical Bulletin

Installation: Bosch Climate 5000 M clearances update in Installation Manual

document number 6721849819 (2024/05)

Currently in the Climate 5000 M installation manual on page 125 (section 2.8.3) there is a section that refers to a 'protection zone'. This is only relevant to appliances that are using R290 refrigerant. The Climate 5000 M uses R32 refrigerant and as such a 'protection zone' is not required.

The product clearances shown on page 600 are the correct clearances the heat pump outdoor unit requires.

This section has the correct clearances (see more on page 600)

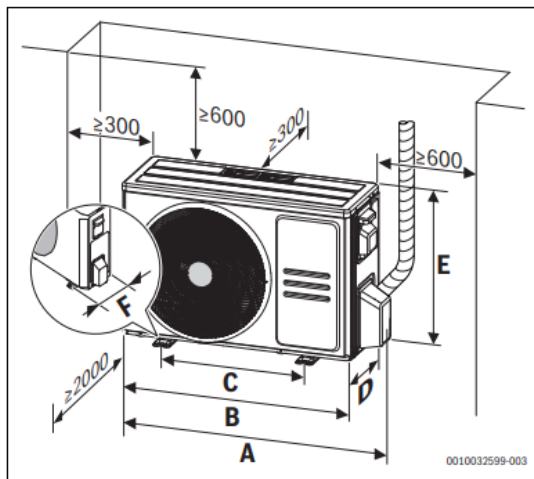

77

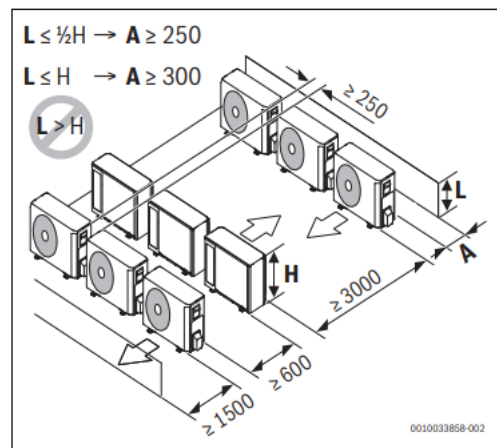

78

	A	B	C	D	E	F
	[mm]	[mm]	[mm]	[mm]	[mm]	[mm]
CL5000M 41/2 E	874	805	511	330	554	317
CL5000M 53/2 E						
CL5000M 62/3 E	955	890	663	342	673	354
CL5000M 79/3 E						
CL5000M 82/4 E	1034	946	673	410	810	403
CL5000M 105/4 E						
CL5000M 125/5 E						

1025

This information is in addition to the information published in the installation manual.

Whilst it is always our intention to fully assist, it is essential to recognise that all information given by the company in response to an enquiry of any nature is provided in good faith and based upon the information provided with the enquiry. We recommend that advice should always be checked with your installer or contract partner. Consequently, the company cannot be held responsible for any liability relating to the use or repetition of such information or part thereof. In addition, whilst making every reasonable effort to monitor the performance and quality of our supply, installation and service network, we do not accept responsibility for the workmanship or operation of any third party company that the company may have promoted either in conversation, e-mail, or other communication. Similarly, the views and opinions expressed in communication with individuals within the company may not reflect that of the business as a whole.

You can find this, and all issued technical bulletins on the Worcester website at: www.worcester-bosch.co.uk/tb
or www.worcester-bosch.ie/tb